

Organic and Biological Chemistry

The Valence Orbitals of Cyclobutane

Roald Hoffmann* and Robert B. Davidson

Contribution from the Department of Chemistry, Cornell University, Ithaca, New York 14850. Received February 27, 1971

Abstract: The highest occupied molecular orbitals of cyclobutane are a degenerate pair of e (SA,AS) symmetry. While not as effective as the corresponding Walsh orbitals of cyclopropane, these valence orbitals of cyclobutane have unique symmetry properties. Thus, when two π -electron acceptor substituents are geminally substituted on a cyclobutane we expect one to assume a bisected conformation, the other a perpendicular one. Geometrical distortions in cyclobutylcarbinyli cations are also predicted. The unusual electronic spectrum of tricyclo[3.3.0.0^{2,6}]-octadiene is attributed to optimum interaction of the ethylene units with the valence orbitals of cyclobutane.

Two models have been especially useful to chemists in interpreting the properties and reactions of molecules containing the cyclopropane ring. Each may be considered a natural extension to three centers of a theoretical description of the ethylenic two-center double bond. The Coulson-Moffitt picture¹ extends the valence bond perfect pairing treatment of the double bond presented by Pauling^{2a} and Slater.^{2b} The carbon-carbon bonds of the ring are constructed by overlapping of hybrid atomic orbitals inclined outward from the internuclear line, producing "bent" bonds. This description has been restated³ in terms of localized molecular orbitals constructed by the criterion of maximum overlap. Both treatments of this model emphasize the "strain energy" inherent in such a "bent" bonding arrangement.

Walsh's⁴ discussion of cyclopropane parallels that of Mulliken⁵ for the σ - π model of the double bond introduced by Hückel.⁶ Trigonal methylene groups are brought together to form the ring by overlap of their σ -

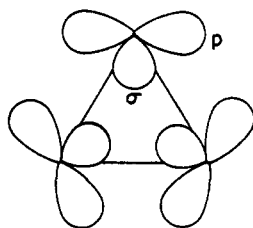

type orbitals at the center and of their p - or π -type orbital around the periphery. The three σ orbitals combine to produce a strongly bonding a_1' level and an antibonding e' pair. The three methylene p orbitals interact less strongly to yield a bonding e' combination and

an antibonding a_2' level.⁷ As the highest occupied orbitals of cyclopropane, the e' orbitals play a crucial role in determining the properties of the molecule.

The e' π -type orbitals are shown in one schematic representation⁸ below and in a contour diagram in Figure

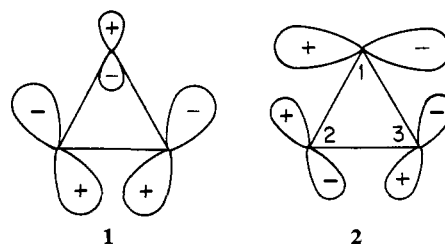

1.⁹ It is clear why cyclopropane is intermediate in its properties between ethylene and unstrained saturated hydrocarbons. The overlap of the component orbitals in the e' set is partly σ , partly π type. The magnitude of the overlap is intermediate between the low value of the pure π overlap of two $2p$ orbitals in ethylene and the large, dominantly σ , overlap of sp^3 hybrids in normal saturated molecules. The cyclopropane e' orbitals are thus at higher energy than the CC σ orbitals of unstrained hydrocarbons but at lower energy than ethylene π orbitals.

Three factors determine the ability of a set of orbitals to interact effectively with other functional groups: (1) the relative energy of the orbitals, (2) their symmetry properties, and (3) the magnitude of their overlap with the interacting groups. If we turn our attention to the second point, we note immediately from the above figures that feature of cyclopropane which has generated the most experimental interest: its ability to conjugate

(1) (a) C. A. Coulson and W. E. Moffitt, *J. Chem. Phys.*, **15**, 151 (1947); (b) C. A. Coulson and W. E. Moffitt, *Phil. Mag.*, **40**, 1 (1949).

(2) (a) L. Pauling, *J. Amer. Chem. Soc.*, **53**, 1367 (1931); (b) J. C. Slater, *Phys. Rev.*, **37**, 481 (1931).

(3) (a) C. A. Coulson and T. H. Goodwin, *J. Chem. Soc.*, 2851 (1962); 3161 (1963); (b) D. Peters, *Tetrahedron*, **19**, 1539 (1963); (c) A. Veillard and G. Del Re, *Theoret. Chim. Acta*, **2**, 55 (1964); (d) L. Klasinc, Z. Maksic, and M. Randić, *J. Chem. Soc. A*, 755 (1966).

(4) (a) A. D. Walsh, *Nature (London)*, **159**, 167, 712 (1947); (b) A. D. Walsh, *Trans. Faraday Soc.*, **45**, 179 (1949); (c) T. M. Sugden, *Nature (London)*, **160**, 367 (1947).

(5) R. S. Mulliken, *Phys. Rev.*, **41**, 751 (1932).

(6) (a) E. Hückel, *Z. Phys.*, **60**, 423 (1930); (b) M. Dunkel, *Z. Phys. Chem., Sect. B*, **10**, 434 (1930).

(7) The extent to which these simple level ordering considerations are preserved in *ab initio* calculations may be judged from (a) H. Basch, M. B. Robin, N. A. Kuebler, C. Baker, and D. W. Turner, *J. Chem. Phys.*, **51**, 52 (1969) and (b) R. J. Buenker and S. D. Peyerimhoff, *J. Phys. Chem.*, **73**, 1299 (1969).

(8) Of course the degeneracy allows alternate choices as linearly independent combinations of those shown.

(9) In most representations the symmetric e' component is portrayed as carrying no contribution at C_1 , as would indeed happen if this orbital were entirely formed from peripheral p orbitals. The picture exhibited here is that resulting upon removal of the latter constraint—the peripheral orbitals then mix in other orbitals, subject only to the group theoretical constraints. The electron density at C_1 is much smaller in this orbital than that at C_2 and C_3 .

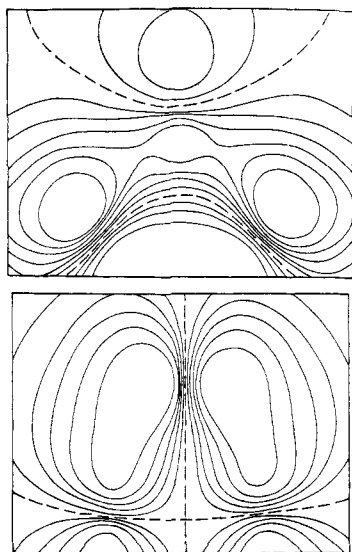

Figure 1. Contour diagram of one representation of the e' highest occupied orbitals of cyclopropane. The cross-section is in the carbon plane with orbital 1 on top, orbital 2 on bottom. Nodal lines are dashed. The wave functions are taken from an extended Hückel calculation.

with adjacent unsaturated and cationic centers. This ability has been explored experimentally in terms of its effects on various types of molecular spectra,^{10,11a} on the conformation of attached unsaturated groups,¹¹ and especially on carbonium ion reactivity.¹²

This effect is most simply illustrated by an interaction diagram for two conformations of cyclopropylcarbiny cation, the bisected geometry and one in which the methylene group is twisted 90° away. This is shown in Figure 2, where the e' levels and the interacting exocyclic p orbital are classified as symmetric or antisymmetric with respect to the mirror plane of the cation. In the bisected conformation the external p orbital overlaps effectively with the A component of e' (2); in the other conformation the symmetry-allowed interaction with the S component 1 is weak because of the deficiency of electron density at C_1 in the latter. A clear preference for the bisected conformation results^{13,14} and is experimentally confirmed.¹⁵

(10) (a) M. Yu. Lukina, *Usp. Khim.*, **31**, 901 (1962) (review); (b) J.-P. Pete, *Bull. Soc. Chim. Fr.*, 357 (1967) (review); (c) W. G. Dauben and G. H. Berezin, *J. Amer. Chem. Soc.*, **89**, 3449 (1967); (d) C. H. Heathcock and S. R. Poulter, *ibid.*, **90**, 3766 (1968); (e) M. J. Jorgenson and T. Leung, *ibid.*, **90**, 3769 (1968).

(11) (a) M. Charton in "The Chemistry of Alkenes," Vol. 2, J. Zabicky, Ed., Interscience, New York, N. Y., 1970 (review); (b) G. J. Karabatsos and N. Hsi, *J. Amer. Chem. Soc.*, **87**, 2864 (1965); (c) L. S. Bartell and J. P. Guillory, *J. Chem. Phys.*, **43**, 647 (1965); (d) J. E. Katon, W. R. Fearheller, Jr., and J. T. Miller, Jr., *ibid.*, **49**, 823 (1968); (e) W. G. Dauben and R. E. Wolf, *J. Org. Chem.*, **35**, 2361 (1970).

(12) An intimidating list of references is given by P. von R. Schleyer and V. Buss, *J. Amer. Chem. Soc.*, **91**, 5880 (1969).

(13) The cyclopropylcarbiny system has been investigated theoretically several times: (a) R. Hoffmann, *J. Chem. Phys.*, **40**, 2480 (1964); (b) T. Yonezawa, H. Nakatsuji, and H. Kato, *Bull. Chem. Soc. Jap.*, **39**, 2788 (1966); (c) K. B. Wiberg, *Tetrahedron*, **24**, 1083 (1968); (d) J. E. Baldwin and W. D. Fogelsohn, *J. Amer. Chem. Soc.*, **90**, 4311 (1968); (e) C. Trindle and O. Sinanoğlu, *ibid.*, **91**, 4054 (1969); (f) K. B. Wiberg and G. Szeimies, *ibid.*, **92**, 571 (1970); (g) L. Radom, J. A. Pople, V. Buss, and P. v. R. Schleyer, *ibid.*, **92**, 6380 (1970).

(14) The conformational dependence and propensity for conjugation can also be deduced from the Coulson-Moffitt model, but in our opinion the deduction is not as straightforward. In fact, for most purposes the Coulson-Moffitt and Walsh pictures may be considered equivalent.^{1b} See W. A. Bennett, *J. Chem. Educ.*, **44**, 17 (1967), for further discussion.

(15) Direct observation of the bisected form of the dimethylcyclopropylcarbiny cation by C. U. Pittman, Jr., and G. A. Olah, *J. Amer. Chem. Soc.*, **87**, 2998 (1965) has been followed by a measurement of an

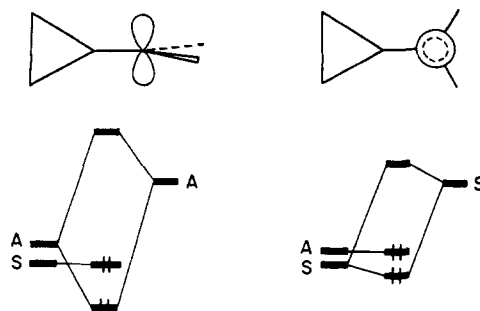

Figure 2. Interaction of the cyclopropane e' orbitals with an external p orbital in the bisected (left) and perpendicular (right) conformations.

Coulson and Moffitt^{1b} applied their bent-bond model to cyclobutane as well as cyclopropane. The various subsequent investigations of localized, bent molecular orbitals^{3,16} similarly included that next higher homolog in their studies. Their conclusion^{1b,3b,3d} was that although cyclobutane has somewhat bent bonds, it should be more like cyclopentane (*i.e.*, normal) than like cyclopropane.

Walsh's main paper on cyclopropane^{4b} mentions the possibility of four-center unsaturation analogous to the three-center unsaturation of cyclopropane, but does not discuss the matter in any detail. Wilson and Goldhamer¹⁷ briefly discuss the possible conjugation of cyclobutane with olefinic systems, invoking " π -like character" in the bent bonds of the ring. Wiberg^{13c} has performed CNDO calculations on the cyclobutylcarbiny cation. A bisected conformation is preferred by 7.4 kcal/mol, which is significantly smaller than the 25.1 kcal/mol barrier computed for cyclopropylcarbiny.^{13c} *Ab initio* calculations yield barriers of 17.5 kcal/mol for cyclopropylcarbiny and 4.1 kcal/mol for cyclobutylcarbiny.^{13g} Early extended Hückel calculations by one of us¹⁸ indicated no special conjugative ability for the cyclobutane ring. Experimental work has not revealed any striking indication of conjugative power by a cyclobutane ring but there is some evidence which suggests that it is not negligible.¹⁹

It is the purpose of this paper to show that while the conjugative ability of a cyclobutane ring is not great it has certain distinctive symmetry properties which may have unusual operational consequences.

The Valence Orbitals of Cyclobutane

The molecular orbitals of cyclobutane have been discussed by several workers^{1b,3,16,20} and most explicitly by Salem and Wright.²¹ We find it instructive to follow the procedure originally outlined by Walsh for cyclopropane.⁴ Consider a planar²² cyclobutane built up from

activation energy for twisting of 13.7 kcal/mol by D. S. Kabakoff and E. Namanworth, *ibid.*, **92**, 3234 (1970).

(16) Z. Maksić, L. Klasinc, and M. Randić, *Theoret. Chim. Acta*, **4**, 273 (1966).

(17) A. Wilson and D. Goldhamer, *J. Chem. Educ.*, **40**, 504 (1963).

(18) R. Hoffmann, *Tetrahedron Lett.*, 3819 (1965).

(19) (a) J. J. Wren, *J. Chem. Soc.*, 2208 (1956); (b) E. G. Treshchova, Yu. N. Panchenko, N. I. Valilyev, M. G. Kuzmin, Yu. S. Shabarov, and R. Ya. Levina, *Opt. Spektrosk.*, **8**, 371 (1960).

(20) T. Yonezawa, K. Shimizu, and H. Kato, *Bull. Chem. Soc. Jap.*, **40**, 456 (1967).

(21) (a) L. Salem and J. S. Wright, *J. Amer. Chem. Soc.*, **91**, 5947 (1969); (b) L. Salem, *Chem. Brit.*, **5**, 449 (1969); (c) J. S. Wright and L. Salem, *Chem. Commun.*, 1370 (1969).

(22) In this section the symmetry designations, as well as the molecular orbitals, are for a planar D_{4h} cyclobutane. The degeneracies and

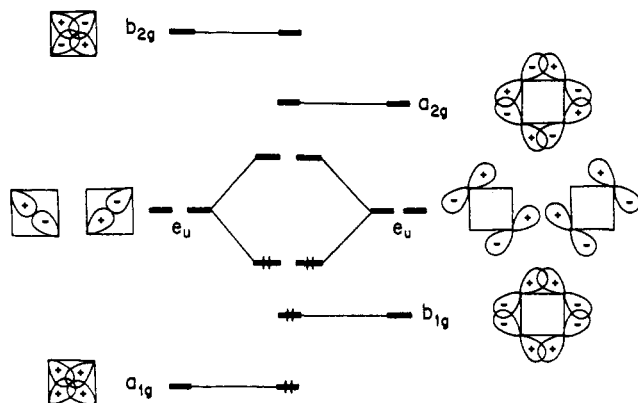
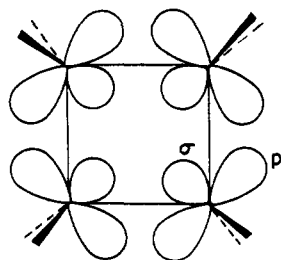

Figure 3. The orbitals of cyclobutane generated from the "in" σ set (left) and "peripheral" p set (right). Note the interaction of the e_u levels derived from each set.

four interacting methylene groups, oriented as shown below. The σ orbitals interact among themselves to



produce bonding a_{1g} , nonbonding e_u , and antibonding b_{2g} levels. The p orbitals may be similarly mixed with each other to yield a bonding b_{1g} , a nonbonding e_u , and an antibonding a_{2g} combination. The shapes of these orbitals are shown in Figure 3, which also illustrates the necessary interaction of the originally nonbonding e_u σ and p sets to produce one bonding e_u and one antibonding e_u . Note the crucial difference from the cyclopropane construction in that for cyclobutane it is an absolute necessity to consider the interaction of σ and p, "in" and "peripheral" orbital sets, in order to obtain four bonding levels.

An equally instructive and perforce equivalent model was constructed by Salem²¹ by starting out with localized CC σ and σ^* orbitals and allowing them to interact. The resultant level scheme is shown in Figure 4. The details of the level ordering and the approximate shape of the orbitals are supported by extended Hückel, CNDO, and *ab initio* calculations as well. All methods agree that the highest occupied orbitals of cyclobutane are a degenerate e_u set with a b_{1g} level not far below.²³ The reason for the relatively high energy of the e_u orbitals is clear—while they are 1-2 and 3-4 σ bonding, they are simultaneously 1-3 and 2-4 π antibonding.²⁴

orbital shapes are retained for the equilibrium geometry of cyclobutane, which is D_{2d} , puckered. The magnitude of the barrier separating the puckered conformations is approximately 1.3 kcal/mol: T. Ueda and T. Shimanouchi, *J. Chem. Phys.*, **49**, 470 (1968), and references therein. (23) The calculations also predict the presence of a high-lying b_{1u} level derived from CH_2 bond orbitals (see ref 21 and P. Bischof, E. Haselbach, and E. Heilbronner, *Angew. Chem.*, **82**, 952 (1970)).

(24) One member of the e_u set is for this very reason the crucial orbital which makes the $2_s + 2_s$ cycloaddition a symmetry-forbidden reaction: R. Hoffmann and R. B. Woodward, *J. Amer. Chem. Soc.*, **87**, 2046 (1965); R. B. Woodward and R. Hoffmann, *Angew. Chem.*, **81**, 797 (1969).

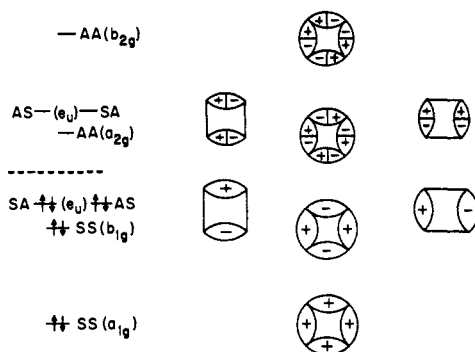

Figure 4. The valence orbitals of cyclobutane, as derived by Salem and Wright.²¹

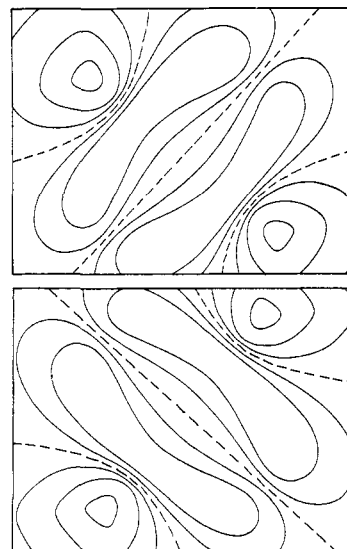
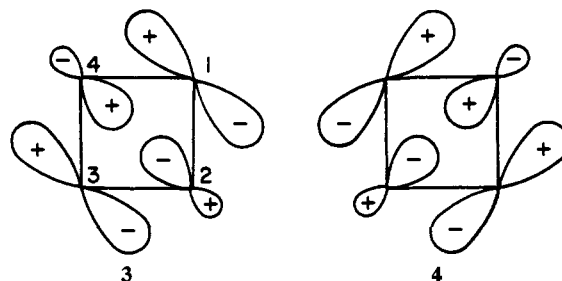

Figure 5. Contour diagram of one representation of the e_u highest occupied orbitals of cyclobutane. The cross-section is in the carbon plane with orbital 3 on top, orbital 4 on bottom. Nodal lines are dashed. The wave functions are taken from an extended Hückel calculation. The contours are more widely spaced than in Figure 1.

The particular choice of e_u orbitals in Figure 4 is of course not unique. The simple expedient of taking a sum and difference of the e_u representatives in Figure 3 yields the equivalent set shown schematically below, and



in a contour diagram in Figure 5. Note the identity of these orbitals to the in-phase combination of the e_u set of noninteracted σ and p levels in Figure 4. Addition of hybrids produces, as it must, a complete equivalence between orbital shapes from the "Walsh" (Figure 3) and Salem (Figure 4) pictures.

In turning to an exploration of the operational consequences of the computed cyclobutane level scheme, we will first show that the shape of the e_u orbitals, com-

pared to that of their e' counterparts in cyclopropane, makes for a smaller conjugative stabilization with a single interacting π system. Consider the bisected conformation **5** and a counterpart **6** in which the exocyclic



methylene group is twisted by 90° . We have already discussed how in the case of cyclopropane the preferential interaction of the methylene p orbital with the ring orbitals in a conformation similar to **5** leads to great stabilization for the bisected form. In cyclobutane the differential between conformations **5** and **6** is much smaller. In either conformation there is significant interaction of the empty p orbital with the occupied ring orbitals: in the bisected conformation **5** with the e_u component **3**, in the perpendicular conformation **6** with the component **4**. The π -type interaction in **5** is still somewhat greater than in **6**. Thus, in our calculations, cyclobutylcarbanyl prefers the bisected conformation by 4 kcal/mol. This is to be compared with 14 kcal/mol for cyclopropylcarbanyl.^{25,26} The stronger conformational preference in cyclopropylcarbanyl stems from several sources. First there is a greater differential in the ability to interact in the two conformations in question. Second, the appropriate ring orbital of cyclopropane may be higher in energy than in cyclobutane.²⁸ Third, the same orbital is more concentrated in the vicinity of the conjugating p orbital than the analogous orbital of cyclobutane.³⁰

The calculated lack of unusual stabilization in cyclobutylcarbanyl species agrees with the experimental evidence on these species.³¹ It would be incorrect to draw from this the inference that cyclobutane is not an interesting conjugating group. First, it is conceivable that in contrast to the cyclopropane case^{12,32} cyclobutylcar-

binyl systems conformationally locked in a perpendicular conformation might exhibit some stabilization. Second, the peculiar properties of the e_u orbitals are best exhibited when two conjugating groups are attached to the cyclobutane skeleton.

Consider the highly hypothetical geminal dicarbonium ions **7** and **8**. In **7** both carbonium ion p orbitals

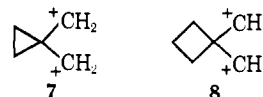

are competing for interaction with the antisymmetric Walsh orbital. It is expected that the bisected-bisected (B,B) conformation **9** should be preferred but that the

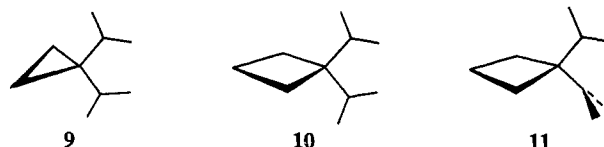

energy gain on bringing the second carbonyl group into a bisecting geometry should be less than for the first group.³³ This is confirmed in the calculations which give the following relative energies (P stands for perpendicular, or 90° twisted from the bisected form¹²): P,P, 15.2; B,P, 4.6; B,B, (0.0) kcal/mol. In **8** the situation is very different. There is no need for both carbonyl groups to compete for the same antisymmetric orbital. Instead, when one carbonyl group is interacting with orbital **3** (assume substitution at upper right of **3**) and taking up a bisected conformation, the other carbonyl group can interact with orbital **4** in the perpendicular conformation. The B,P geometry **11** is thus stabilized over the B,B geometry **10**. This is confirmed in the calculations: P,P, 1.8; B,P, (0.0); B,B, 0.2 kcal/mol.

Table I presents some further conformational energies for two carbonyl groups substituted in various ways on a cyclopropane or cyclobutane. No great signifi-

(25) Somewhat different energies, but in a similar ratio, were obtained in CNDO calculations in ref 13c, and in *ab initio* calculations in ref 13g.

(26) The geometries used were those of the unsubstituted hydrocarbons (ref 27), with the carbonium carbon placed 1.50 Å along the direction of the C-H bond it replaces, and the carbonium hydrogens at a distance of 1.10 Å and an HCH angle of 117° with respect to that carbon.

(27) (a) Cyclopropane: O. Bastiansen, F. N. Fritsch, and K. Hedberg, *Acta Crystallogr.*, **17**, 538 (1964); (b) cyclobutane: J. D. Dunitz and V. Schomaker, *J. Chem. Phys.*, **20**, 1703 (1952); (c) A. Almennigen, O. Bastiansen, and P. N. Skancke, *Acta Chem. Scand.*, **15**, 711 (1961); (d) R. C. Lord and B. P. Stoicheff, *Can. J. Phys.*, **40**, 725 (1961); (e) T. N. Margulis, *Acta Crystallogr.*, **19**, 857 (1965).

(28) In the calculations the HOMO energies are nearly equal. The Jahn-Teller components in the cyclobutane photoelectron spectrum fall at 10.7 and 11.3 eV;²⁹ those of cyclopropane are at 10.53 and 11.3 eV.^{7a}

(29) See Bischof, *et al.*, ref 23.

(30) This is a consequence of normalization and symmetry. If τ_1 , τ_2 , and τ_3 are the appropriately oriented p orbitals on carbons 1, 2, and 3 of cyclopropane, then (neglecting overlap) the conjugating pseudo- π orbital $\psi_a \sim 1/\sqrt{6}(2\tau_1 - \tau_2 + \tau_3)$. If γ_1 , γ_2 , γ_3 , and γ_4 are the appropriately oriented p orbitals on carbons 1, 2, 3, and 4 of cyclobutane (**3**) then (neglecting overlap and s character) $\psi_a \sim 1/2(\gamma_1 + \gamma_2 + \gamma_3 + \gamma_4)$. The approximate relative contributions of the p orbitals adjacent to the carbonium center are thus $2/\sqrt{6}:1/2 \sim 1.6$.

(31) (a) C. F. Wilcox and M. E. Mesirov, *J. Amer. Chem. Soc.*, **84**, 2757 (1962); (b) R. C. Hahn, T. F. Carbin, and H. Shechter, *ibid.*, **90**, 3404 (1968); (c) R. Breslow in "Molecular Rearrangements," P. de Mayo, Ed., Interscience, New York, N. Y., 1963, p 233, and references therein; (d) W. G. Dauben, J. L. Chitwood, and K. V. Scherer, Jr., *J. Amer. Chem. Soc.*, **90**, 1014 (1968); (e) J. J. Gajewski, R. L. Lyle, and R. P. Gajewski, *Tetrahedron Lett.*, 1189 (1970).

(32) J. C. Martin and B. R. Ree, *J. Amer. Chem. Soc.*, **91**, 5882 (1969).

Table I. Conformational Energies of Dicarbonyl Dications

Molecule	Conformation ^a	E_T^b	E_{rel}^c
<i>cis</i> -1,2-Cyclopropyl	B,B	-469.80	0.0
	B,P	-469.31	11.3
	P,P	-468.73	24.7
<i>trans</i> -1,2-Cyclopropyl	B,B	-469.93	0.0
	B,P	-469.35	13.4
	P,P	-468.78	26.5
<i>cis</i> -1,2-Cyclobutyl	B,B	-574.76	0.0
	B,P	-574.60	3.7
	P,P	-574.30	10.6
<i>trans</i> -1,2-Cyclobutyl	B,B	-574.93	0.0
	B,P	-574.69	5.5
	P,P	-574.53	9.2
<i>cis</i> -1,3-Cyclobutyl	B,B	-574.89	0.0
	B,P	-574.72	3.9
	P,P	-574.47	9.7
<i>trans</i> -1,3-Cyclobutyl	B,B	-574.90	0.0
	B,P	-574.73	3.9
	P,P	-574.48	9.7

^a B \equiv bisected; P \equiv perpendicular. ^b From extended Hückel calculations, electron volts/molecule. ^c Kilocalories/mole relative to lowest energy conformer.

(33) One might think there would be a close H-H contact in the B,B conformation, but with our geometrical parameters that distance is 2.5 Å.

cance is to be attached to the relative stabilities of different isomers, but the energies of the various conformations for a given isomer are highly interesting. The following observations can be made. (1) There is no significant difference between the patterns of cis and trans isomers, which is understandable if symmetry is the controlling factor. (2) The cis and trans 1,2-cyclopropyl and 1,2-cyclobutyl species **12** and **13** show similar defi-

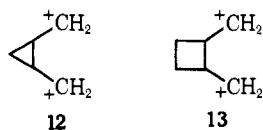

nite preferences for bisected-bisected conformations. In the case of **13** this is in marked contrast to the 1,1-cyclobutyl case and requires explanation. Consider two carbinyl groups in a bisected conformation attached cis 1,2 on a cycloalkane (**14**). From the carbinyl p orbitals

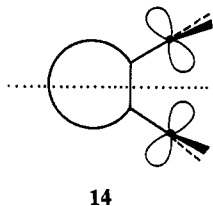

one can form two combinations, symmetric and antisymmetric with respect to the indicated mirror plane.³⁴ The cyclopropane and cyclobutane each possess one component symmetric, one antisymmetric with respect to the same mirror. Both components interact, and do so preferentially in the bisected geometry. (3) The 1,3-cyclobutyl cases both prefer a bisected-bisected geometry, **15**. This is at first sight puzzling since the same

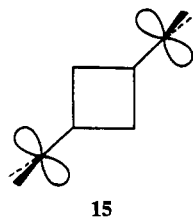

argument that was used for favoring a bisected, perpendicular arrangement for 1,1-cyclobutyl would seem to be applicable here. Examination of the wave functions reveals that in the bisected form both the S and A combinations of methylene orbitals mix with ring orbitals. The S combination mixes with the symmetric component of e_u (orbital **3**) and the A combination with the b_{1g} orbital (see Figure 3) which lies not far below. In another way of looking at this problem we can form the sum and difference of the above-mentioned two ring orbitals, **3** and b_{1g} , to obtain two localized orbitals **16** and **17**. These are obviously disposed for stabilizing an

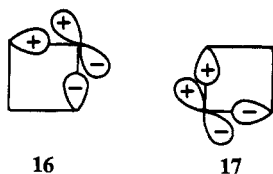

ion bisected both at C-1 and at C-3.

(34) In a trans 1,2 compound this mirror plane would be replaced by a twofold rotation axis.

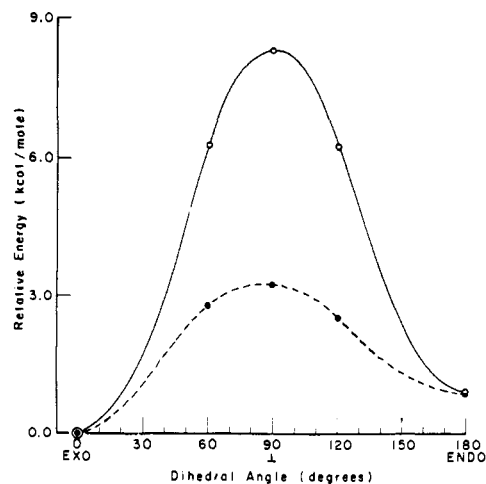
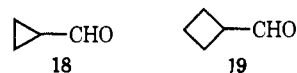

Figure 6. Extended Hückel potential energy curves for cyclopropanecarboxaldehyde (solid line) and cyclobutanecarboxaldehyde (dashed line).

The dications, while providing the ultimate in electron-accepting capability, are hardly realistic molecules. We therefore turned to the more realistic carboxaldehydes exemplified by **18** and **19**.³⁵ The results are



shown in Figure 6.

Both compounds show a distinct preference for bisected conformations, with endo and exo orientations about equally favored. In the case of the cyclopropyl compound, for which gas-phase data are available,^{11c} this is in good qualitative agreement with experiment. In these molecules the preference for bisected conformations arises from interaction of the pseudo- π ring orbitals with the low-lying π^* orbital of the carbonyl group. The interaction is smaller than in the corresponding cations because the antibonding π^* orbital is spread out over two centers instead of the one of the "empty" cationic p orbital and because the formally nonbonding cationic p lies lower in energy than the antibonding π^* . It is not much smaller, however, because the π^* orbital is but little higher in energy than the nonbonding p and is concentrated in the region of the carbon atom.

An electron diffraction study of cyclobutanecarboxylic acid chloride³⁶ shows the clear predominance of a gauche conformer ($\theta = 120^\circ$ in our convention). Though intuitively one would expect such a three-center π system to have weaker conformational preferences than the one- and two-center ones considered above, we do not yet know with any certainty what perturbations chlorine substitution might produce.

Extensive calculations were also carried out on the 1,1- and 1,2-cyclopropanedicarboxaldehydes and the 1,1-, 1,2-,

(35) Ring geometries were chosen as for the cations discussed previously. Aldehydic carbon atoms were placed 1.50 Å along the CH bonds they replace, the aldehyde CH and CO distances were 1.11 and 1.22 Å, respectively, and the CCH and CCO angles were 117.5 and 123.9°, respectively. The dihedral angle between aldehyde C=O and ring CH was varied between 0 (O exo) and 180° (O endo).

(36) W. J. Adams and L. S. Bartell, *J. Mol. Struct.*, **8**, 199 (1971). It should be noted that previous calculations by one of us (ref 18) produced a potential energy curve qualitatively different from that in Figure 6. The primary difference between those calculations and the ones reported here is the orbital exponent assigned to hydrogen. It is disturbing that the results are sensitive to this parameter.

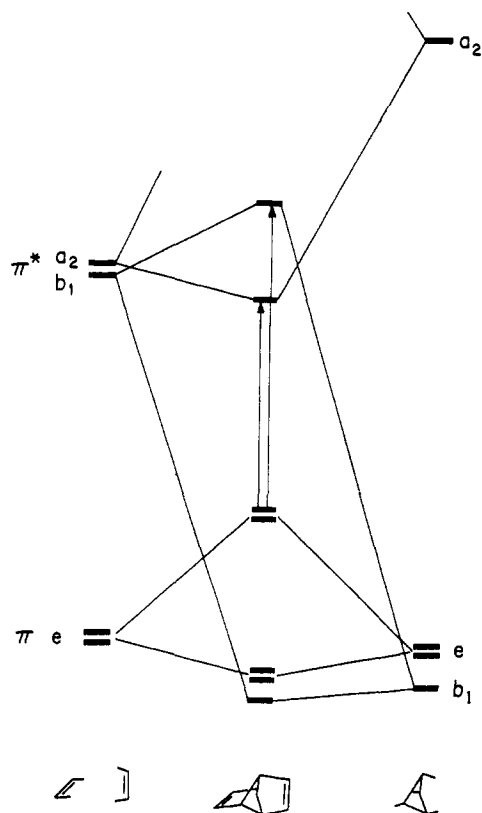

Figure 7. Interaction diagram for the mixing of ethylene orbitals (left) with cyclobutane orbitals (right) in tricycloocta[3.3.0.0^{2,6}]-octadiene. Note that the cyclobutane orbitals of Figure 4 have now been classified in D_{2d} symmetry. The arrows indicate allowed electronic transitions.

and 1,3-cyclobutanedicarboxaldehydes. The electronic effects for the dicarbonium ions are generally followed in these molecules, though expectedly attenuated and occasionally masked by overriding steric factors. Thus, in the geminal cyclopropane compound some 10 kcal/mol separate the most favored conformation (B,B, both oxygens exo) from the least favored (P,P). In contrast, in the geminal cyclobutane compound less than 2 kcal/mol separate any pair of conformations. In the 1,2 isomers the conformer-energy differentiation, favoring the B,B, both oxygens exo, is restored, though in the cis 1,2 there are some conformations obviously destabilized by close contacts.

The experimental evidence on cyclobutanes substituted with several conjugating groups is ambiguous. The information we have is from crystallographic studies, where crystal packing energies could easily overcome the small energetic preferences we calculate. *cis,trans,cis*-1,2,3,4-Tetraphenylcyclobutane has two phenyl rings in the bisecting conformation, two skewed.³⁷ The carbomethoxy groups in *cis*- and *trans*-1,2-dibromo-1,2-dicarbomethoxycyclobutane occupy skewed positions.³⁸ *trans*-1,3-Cyclobutanedicarboxylic acid also has skewed carboxylic acid groups.^{39a} Crystals of $\text{Na}_2\text{C}_4\text{H}_6(\text{COO})_2 \cdot 2\text{C}_4\text{H}_6(\text{COOH})_2$ have nearly bisected carboxylic acid groups in the acid molecules and nearly perpendicular carboxylate groups in the anion.^{39b}

(37) J. D. Dunitz, *Acta Crystallogr.*, **2**, 1 (1949); T. N. Margulis, *ibid.*, **19**, 857 (1965).

(38) I. L. Karle and K. Britts, *J. Amer. Chem. Soc.*, **88**, 2918 (1966).

(39) (a) T. N. Margulis and M. S. Fisher, *ibid.*, **89**, 223 (1967); (b) E. Adman and T. N. Margulis, *ibid.*, **90**, 4517 (1968).

Other Consequences of the Cyclobutane Valence Orbitals

The unique symmetry properties of the valence orbitals of cyclobutane rationalize and predict other interesting phenomena. (1) Consider again the bisected and perpendicular conformations of cyclobutylcarbonyl, **5** and **6**, but now imagine some structural constraint which holds these cations strictly in these conformations. Interaction in the bisected conformation is accompanied by electron transfer out of orbital 3. This decreases 2-4 antibonding, and this in turn should allow C-2 and C-4 to approach each other, resulting in a molecular distortion shown in **20**. In the perpendicular conformation **21** electron transfer occurs out of orbital 4. This



decreases 1-3 antibonding, with consequent distortion as in **21**.

(2) The highly strained tricyclooctadiene **22**, a valence isomer of cyclooctatetraene, has recently been prepared.⁴⁰ Compound **22** has a remarkable electronic

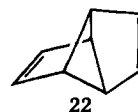

spectrum for a formally nonconjugated diene, with absorption beginning at about 320 μm . We attribute the red shift of this spectrum to the interaction of the double bonds with the cyclobutane orbitals. First note that the cyclobutane orbitals **3** and **4** are beautifully set up for conjugation with π -electron systems spanning the 1-3 and 2-4 positions. The details of the interaction are worked out in Figure 7. Note that the ethylene π orbitals, of e symmetry in D_{2d} , are not split by the interaction with the cyclobutane. Instead they mix strongly with the cyclobutane $e(e_u)$ orbital with one component significantly destabilized. The ethylene π^* orbitals are split by interaction with cyclobutane b_1 and a_2 orbitals.⁴¹

(3) Molecules with several fused cyclobutane rings should, by an extension of our considerations for cyclobutane itself, possess some high-lying σ orbitals. In laterally fused structures such as **23** one specific orbital

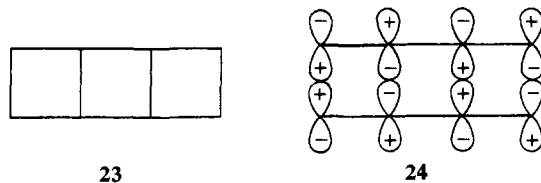

should be at especially high energy. This is **24**, a σ -bonding orbital which is as π antibonding as possible.⁴² The symmetry properties of these orbitals coupled with their predicted high energy should provide the opportunity for some interesting interactions with coupled π -electron systems.

(40) J. Meinwald and H. Tsuruta, *ibid.*, **91**, 5877 (1969); **92**, 2579 (1970).

(41) This molecule has also been discussed by R. Gleiter, University of Basel, private communication.

(42) There is, of course, an analogous σ -bonding, π -antibonding orbital which runs perpendicular to **24**. The relative energy of these orbitals may differ in the syn and anti stereoisomers.

Acknowledgment. R. B. D. was the recipient of a National Institutes of Health Postdoctoral Fellowship during the course of this work. We are grateful

to the National Science Foundation (GP 8013) and the National Institutes of Health (GM 13468) for support of this research.

A Simple Model for Linear Salt Effects in Solvolysis Reactions

Charles L. Perrin*¹ and Jeff Pressing

Contribution from the Department of Chemistry, University of California, San Diego, La Jolla, California 92037. Received January 28, 1971

Abstract: The rate-enhancing effect of added salts on solvolysis reactions in less polar solvents can be accounted for by a simple statistical-mechanical model, based on dipole-dipole interaction between the salt and the transition state. This model provides a satisfactory explanation for the concentration dependence. The calculated variations of the salt effect with solvent, salt, and temperature are in good agreement with experiment. Especially noteworthy is the ability of the model to rationalize the specificity of the various salts solely in terms of dipole-dipole interactions and to dissect the salt effect into enthalpy and entropy contributions. Two comments on the special salt effect are included, one concerning its origin and the other concerning its implication for the lifetimes of intermediates in solvolysis.

For many years chemists have been interested in the effects of salts on reaction rates.² Considerable effort has been devoted to understanding salt effects in polar solvents, but it is clear that there are many factors possibly operative—electrostatic and ion-atmosphere stabilization,³⁻⁵ “drying” of solvent,⁶⁻⁸ specific salt-induced medium effects,^{5,9,10} and micelle formation.¹¹ Salt effects in less polar solvents have received less attention, although there have been interpretations involving specific interactions,^{12,13} basicity,^{14,15} and suppression of ion-pair return (the “special” salt effect).¹⁶

We now wish to present a new interpretation of a class of salt effects, namely, the “normal” salt effects in less polar solvents. In a series of papers, Winstein and coworkers have reported extensive studies of the dependence of solvolysis rates of arenesulfonates on the concentrations of added salts.¹⁷ They consistently

found that “normal” salt effects could be fit to the equation

$$k = k_0(1 + b[\text{MY}]) \quad (1)$$

where k is the solvolysis rate constant in the presence of a concentration $[\text{MY}]$ of added salt and b is a parameter varying with solvent, arenesulfonate, added salt, and temperature. Similar results have been reported by Salomaa¹² for the effects of added salts on alcoholysis rates of 1-halo ethers in various mixed solvents. Several qualitative and semiquantitative interpretations of such salt effects have been presented,^{4,5,12,13,18} but none has been pursued very extensively. Nor has any satisfactory explanation of the concentration dependence, the effect of solvent, the specificity of salts, or the temperature dependence been offered. In view of the well-known success³ of the Debye-Hückel theory in explaining salt effects on ionic reactions in aqueous solution, we thought that an analogous approach might explain the salt effects on solvolyses. However, in the less polar solvents employed, the salts are not dissociated to ions, but are present as ion pairs. (For example, the evidence for the state of LiClO_4 in acetic acid has been summarized.¹⁶) Also, the transition state is a dipole, rather than an ion. Therefore it is necessary to treat these salt effects on the basis of dipole-dipole interactions. In this paper it is shown that a simple statistical mechanical model for treating the interaction between the transition state and the added salt can provide a reasonable approach to the interpretation of b in terms of microscopic parameters.

Theory

According to the Brønsted rate law, k , the rate constant in the presence of added salt, is increased over k_0 , the rate constant in the absence of salt, because salts decrease γ_{\ddagger} , the activity coefficient of the dipolar transition state (eq 2). Here we have neglected the

(18) E. D. Hughes, C. K. Ingold, S. F. Mok, S. Patai, and Y. Pocker, *J. Chem. Soc.*, 1265 (1957).

- (1) Alfred P. Sloan Research Fellow, 1967-1969.
- (2) For a recent review see L. P. Hammett, “Physical Organic Chemistry,” 2nd ed, McGraw-Hill, New York, N. Y., 1970, Chapter 7, pp 187-219.
- (3) V. K. La Mer, *Chem. Rev.*, 10, 179 (1932).
- (4) L. C. Bateman, M. G. Church, E. D. Hughes, C. K. Ingold, and N. A. Taher, *J. Chem. Soc.*, 979 (1940).
- (5) G. Kohnstam, *Chem. Soc., Spec. Publ.*, No. 19, 148 (1965).
- (6) G. R. Lucas and L. P. Hammett, *J. Amer. Chem. Soc.*, 64, 1928 (1942).
- (7) C. G. Swain, T. E. C. Knee, and A. MacLachlan, *ibid.*, 82, 6101 (1960).
- (8) P. Beltramé, C. A. Bunton, A. Dunlop, and D. Whittaker, *J. Chem. Soc.*, 658 (1964).
- (9) E. F. J. Duynstee, E. Grunwald, and M. L. Kaplan, *J. Amer. Chem. Soc.*, 82, 5654 (1962).
- (10) G. A. Clarke and R. W. Taft, *ibid.*, 84, 2295 (1962).
- (11) E. F. J. Duynstee and E. Grunwald, *Tetrahedron*, 21, 2401 (1965).
- (12) P. Salomaa, *Ann. Univ. Turku., Ser. A*, 14, (1953).
- (13) (a) A. H. Fainberg and S. Winstein, *J. Amer. Chem. Soc.*, 78, 2763 (1956); (b) *ibid.*, 78, 2780 (1956); (c) S. Winstein, E. C. Friedrich, and S. Smith, *ibid.*, 86, 305 (1964).
- (14) P. A. O. Virtanen, *Suom. Kemistilehti B*, 38, 231 (1965).
- (15) S. D. Ross, *Tetrahedron*, 25, 4427 (1969).
- (16) S. Winstein, P. E. Klinedinst, Jr., and G. C. Robinson, *J. Amer. Chem. Soc.*, 83, 885 (1961).
- (17) E. L. Allred and S. Winstein, *ibid.*, 89, 4012 (1967), and previous papers.